

# OIL LEVEL INDICATORS NFG Series



The Normal Face Gauge  
for Oil Immersed Power Transformers



## 1.0 Features

The magnetic oil level indicators type NFG has been specially studied for use on power transformer to give an analogical indication of the oil level inside the conservator by a graduated dial with arrow plus one or more electric signal (max 4 signals) when the oil inside the conservator reaches the max or min level.

## 2.0 Construction features

### Materials and components

The body of the gauge is made in one piece of solid compact aluminium alloy casting oil tightened proof.

The indicating system is located inside the body and is composed by a yellow arrow, a graduated scale, one or more contacts activated by cams and a permanent magnet.

The monitoring system is located behind the fixing flange (it is fully inside the conservator, this in order to minimize the external protrusion of the gauge itself from the conservator tank) and is composed by a permanent magnet, rigidly connected (or by means of a bevel gear for form Y) to a float arm which follows the movement of the surface of the oil.

The two systems are connected by a magnetic joint through the magnetic flux of the permanent magnets.

The electric signal coming from the contacts are carried out through a waterproof terminal box (IP65) with a M25x1.5 threaded entry (see page NFG5).

Upon request we can supply adaptors M25x1.5 to M20x1.5 or to PG16.

Also upon request we can supply cable glands M25x1.5 or M20x1.5 or PG16.

### Oil-tightness and resistance to pressure

The magnetic oil level indicators NFG are leak tested (routine test) and are mechanically resistant to vacuum (10 torr).

### Resistance to dynamical stress

The magnetic oil level indicators NFG can operate without undue operation in following conditions:

Sinus vibrations with frequency  $\leq 120$  Hz and amplitude  $\leq 250$   $\mu\text{m}$ ;

Dynamical conditions causing following accelerations:

- Max 3g in all directions, sinus vibration, amplitude  $\leq 20$  mm;
- Shock condition with max 10 g in all directions.

### Surface protection

Body, frame, terminal box and his cover are painted internally and externally with one primer coat of epoxy paint and externally with a finishing coat of polyurethane paint colour RAL 7030. The primer coat on the internal surfaces is compatible with transformer mineral oil up to temperatures of 120°C. Total thickness of two coats is 80 microns; upon request we can supply gauges with special painting for transformers located in very polluted areas.

## 3.0 Manufacturing program

Magnetic oil level indicator series NFG is manufactured in 3 sizes with 2 different styles:

- Size 1: flange OD 140mm; Dial ND 100mm (4 inches);
- Size 2: flange OD 220mm; Dial ND 150mm (6 inches);
- Size 3: flange OD 345mm; Dial ND 250mm (10 inches);
- Style Y: axial float arm suitable for use on traditional breathing conservator and on hermetic conservator with rubber bag
- Style R: radial float arm suitable for use on traditional breathing conservator.

All execution are fitted with 1 or more electric contacts, microswitch type, that are activated when the oil (and consequently the arrow of the instrument) reaches the presetted positions (see available wiring diagram).

The indicating arrow in type "R" moves over a 140° angle, the float arm moves over an angle of 140°.

The indicating arrow in type "Y" moves over a 140° angle, the float arm moves over an angle of 60°.

The gauge type "Y" has a special design that allow the mounting of the same gauge either in the centre of the conservator end, or the bottom of the conservator end, or inclined below the conservator, just fixing the float arm in a specific way without any special adjustment (see sketch page NFG6)

The standard Indicating dial has 10 divisions with yellow figures other dials are available (see page NFG6).

## 4.0 Operation, installation and maintenance

### Operation

The float arm detects an increase (due to heating) or a decrease (due to an oil loss) of oil inside the conservator, giving a visible indication (analogical type) through the arrow and when the oil reaches the presetted value for alarm and/or trip a microswitch is activated and an electric signal is provided inside the terminal box.

### Installation

Use one magnetic oil level indicator for the conservator of the main tank and one for OLTC conservator (if present); the oil level indicator can be fixed to the conservator using studs & nuts (type B) or screws (type V) M6 (6 pcs) or M10 (8 pcs) with washer and spring washer (see the page NFG5).

### Adjusting float arm length

NFG form Y are supplied with adjustable float arm length; this in order to have an optimal calibration of the instrument. Adjustment is very easy: you need only to unloose screw A (please refer to page NFG5), adjust float arm to desired length and close screw A again.

### Maintenance

Magnetic oil level gauges NFG don't need specific maintenance; we suggest to check regularly contacts during the normal maintenance of the transformer.

## 5.0 Electric contacts

The contacts are microswitches changeover type and are mechanically operated by a cam.

Following main characteristic of micro switches:

Lever	Stainless steel
Body and pushbutton	Thermosetting composition
Contact material	Silver
Mechanical endurance of contact	1x10 <sup>6</sup> cycles
Temperature range	-40°C - +125°C
Standard interruption power AC	AC 250V-5A
Standard interruption power DC	see diagram at page NFG5
Insulation to earth at 20°C	2.000V
Protection degree of terminal box	IP 55

## 6.0 Wiring diagrams

Available wiring diagram are (see page NFG5):

- wiring diagram type C1 : gives a signal when oil reaches low level inside conservator
  - wiring diagram type C2 : gives a signal when oil reaches low or max level inside conservator
  - wiring diagram type D1 : gives an alarm signal when oil reaches low level and trip signal for very low level inside conservator
  - wiring diagram type D2 : gives a double signal when oil reaches low level inside conservator
  - wiring diagram type D4 : gives a double signal when oil reaches low or max level inside conservator
- All contacts are operated 3/5 degrees before the arrow reaches the minimum or the maximum level of oil.

## 7.0 Compatibility of installation

The installation compatibility of the magnetic oil level indicator depend mainly on the climatic conditions related to ambient temperature and oil temperature (that influence choice of the material used for the flange gasket) and on environmental conditions (that influence choice of the material used for front dial and fittings) ; therefore the executions differ because of the different materials used for gaskets; front dial and fittings.

### Execution related to climatic conditions:

#### N – O/RING made in HNBR (hydrogenated nitrile rubber)

This is standard execution on sizes 1 & 2

Admitted operating conditions are:

#### Environmental conditions:

Ambient temperature: -40°C to +55°C

Relative humidity: 95% to 20°C - 80% to 40°C - 50% to 50°C

**Insulating liquid** (transformer mineral oil):

Temperature: - 40°C to + 140°C

#### C – NBC Cork gasket (flat flange gasket with 6 or 8 holes instead of O-Ring gasket)

This is standard execution on size 3 and on demand on sizes 1 & 2

Admitted operating conditions are:

**Environmental conditions:**

Ambient temperature: -20°C to +50°C

Relative humidity: 95% to 20°C - 80% to 40°C - 50% to 50°C

**Insulating liquid** (transformer mineral or silicon oil):

Temperature: - 20°C to + 110°C

**G – LT Cork gasket (flat flange gasket with 6 or 8 holes instead of O-Ring gasket)**

This execution is on demand on all sizes for low temperature applications

Admitted operating conditions are:

**Environmental conditions:**

Ambient temperature: -55°C to +50°C

Relative humidity: 95% to 20°C - 80% to 40°C - 50% to 50°C

**Insulating liquid** (transformer mineral or silicon oil):

Temperature: - 55°C to + 160°C

**Execution related to environmental conditions:**

**0 – For normal and tropical conditions**

Front dial made in P.M.M.A.; fittings made in brass nickel plated and s/steel AISI 304

**7 – For desert conditions and / or moderated corrosive conditions**

Front dial made in tempered glass; fittings made in brass nickel plated and s/steel AISI 304

**8 – For extremely corrosive conditions**

Front dial made in tempered glass; fittings made in brass nickel plated and s/steel AISI 316

**Special executions**

For other environmental and/or operating conditions to be examined individually.

## 8.0 Ordering Instructions

When ordering must be defined following data (see order form at page 10 of catalogue):

- Style of magnetic oil level indicator : R or Y
- Size 1 (flange OD 140 mm); 2 (flange OD 220 mm); or 3 (flange OD 345 mm)
- Mounting sketch (for R style always A);
- Wiring diagram: C1; C2; D1; D2; D4;
- Climatic conditions (type of gasket: N; C; G or special);
- Environmental conditions (0; 7; 8 or special);
- Type of dial : 0; 1; 5; or special;
- Special requirement i.e. Cable Entry.

Example : to order 5 magnetic oil level indicator type NFG form Y, OD 220mm, mounting on traditional conservator, 2 contacts SPDT at min and max level, with HNBR gaskets, normal environmental conditions and dial marking Min, -20, 20, 85, Max, write:

- Nr. 5 Magnetic oil level indicator NFG Y2AC2N00.

## 9.0 Marking on data plate

All our magnetic oil level indicator have a data plate with S/N and model of the instrument

Example : on above oil level gauge type NFG form Y, OD 220mm, mounting on traditional conservator, 2 contacts SPDT at min and max level, with HNBR gaskets, normal environmental conditions and dial marking Min, -20, 20, 85, Max, will have the following marking engraved on field Type: Y2AC2N00.

FILE = 3830 .DWG LMF [(0,0) (196,286)] A4 (210x297) REV. 01 DTD 22/02/16 La CEDASPE S.p.A. si riserva a termini di legge la proprietà del presente disegno con divieto di riprodurlo o comunicarlo a terzi senza sua autorizzazione.

**WIRING DIAGRAM**

**WIRING DIAGRAM C1 - (MIN CONTACT)**

Only min contact  
 \*) Min contact operates in this area

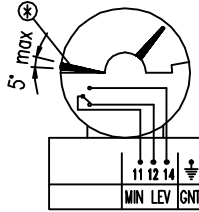

**WIRING DIAGRAM C2 - (MIN & MAX CONTACT)**

Min & max contact  
 \*) Min contact operates in this area  
 \*\*) Max contact operates in this area

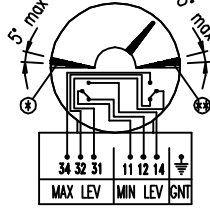

**WIRING DIAGRAM D1 - TWO MIN (ALARM & TRIP CONTACT)**

Alarm contact low level  
 Trip contact very low level  
 \*) Trip contact operates in this area  
 \*\*) Alarm contact operates in this area

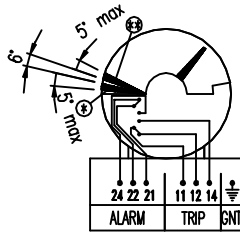

**WIRING DIAGRAM D2 - (DOUBLE MIN CONTACT)**

Double contact at min level  
 \*) Both contacts operate in this area

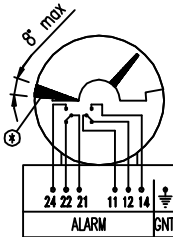

**WIRING DIAGRAM D4 - (DOUBLE MIN + MAX CONTACT)**

Double contact at min and max level  
 \*) Both Min contacts operate in this area  
 \*\*) Both Max contacts operate in this area

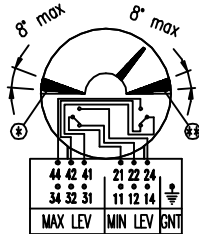

**ADJUSTABLE FLOAT ARM (ROLLING FLOATS)**

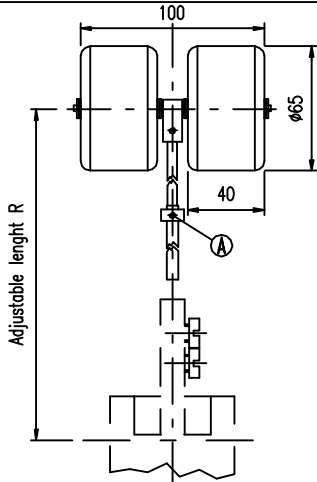

FOR "Y" STYLE SKETCH B, C, H & K

**FIXING SKETCHS**

NFG 5

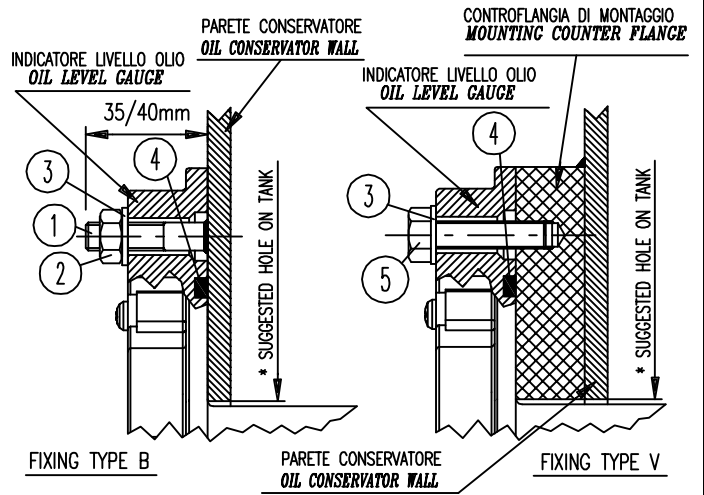

* SUGGESTED HOLE		
ø85	ø120	ø200
NFG1	NFG2	NFG3

5	SCREW M6	SCREW M10	SCREW M12
4	O-RING GASKET	O-RING GASKET	FLANGE GASKET
3	WASHER M6	WASHER M10	WASHER M12
2	NUT M6	NUT M10	NUT M12
1	STUD M6	STUD M10	STUD M12
POS.	NFG1	NFG2	NFG3

**CONTACT BREAKING CAPACITY DC**

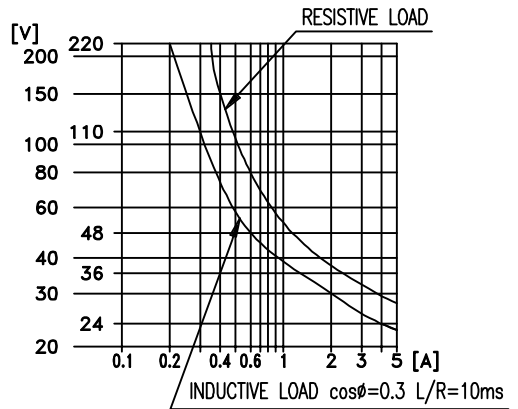

**OPTIONS FOR CABLE ENTRIES M25x1.5**

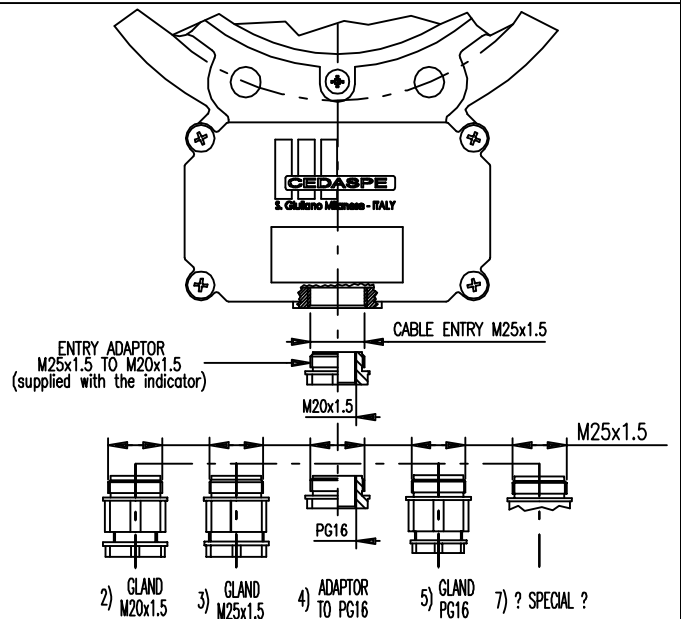

Titolo

Magnetic oil level indicator NFG

Data 12/03/13

Scala ==

Dis.

Visto

Dis. Nr

3830

1

**CEDASPE**

### STANDARD DIALS

NFG 6

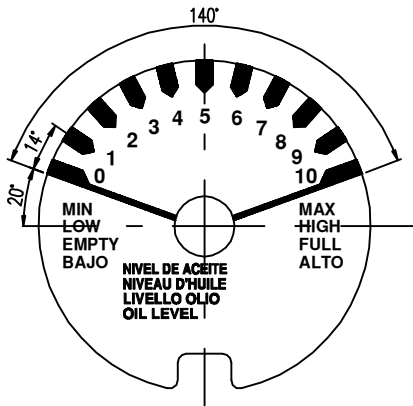

TYPE "1"

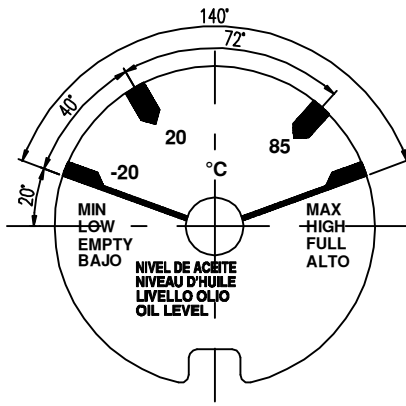

TYPE "0"

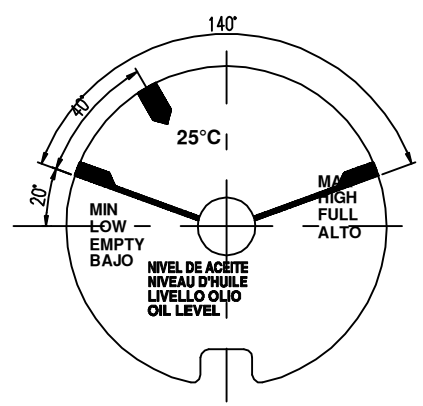

TYPE "5"

### MOUNTING SKETCH NFG-R

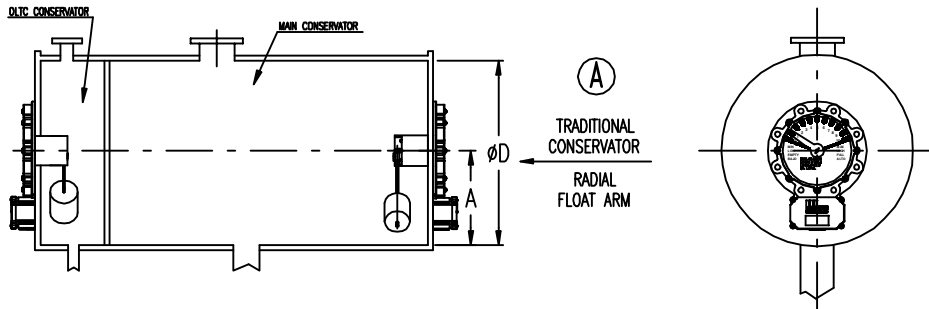

### MOUNTING SKETCHS NFG-Y

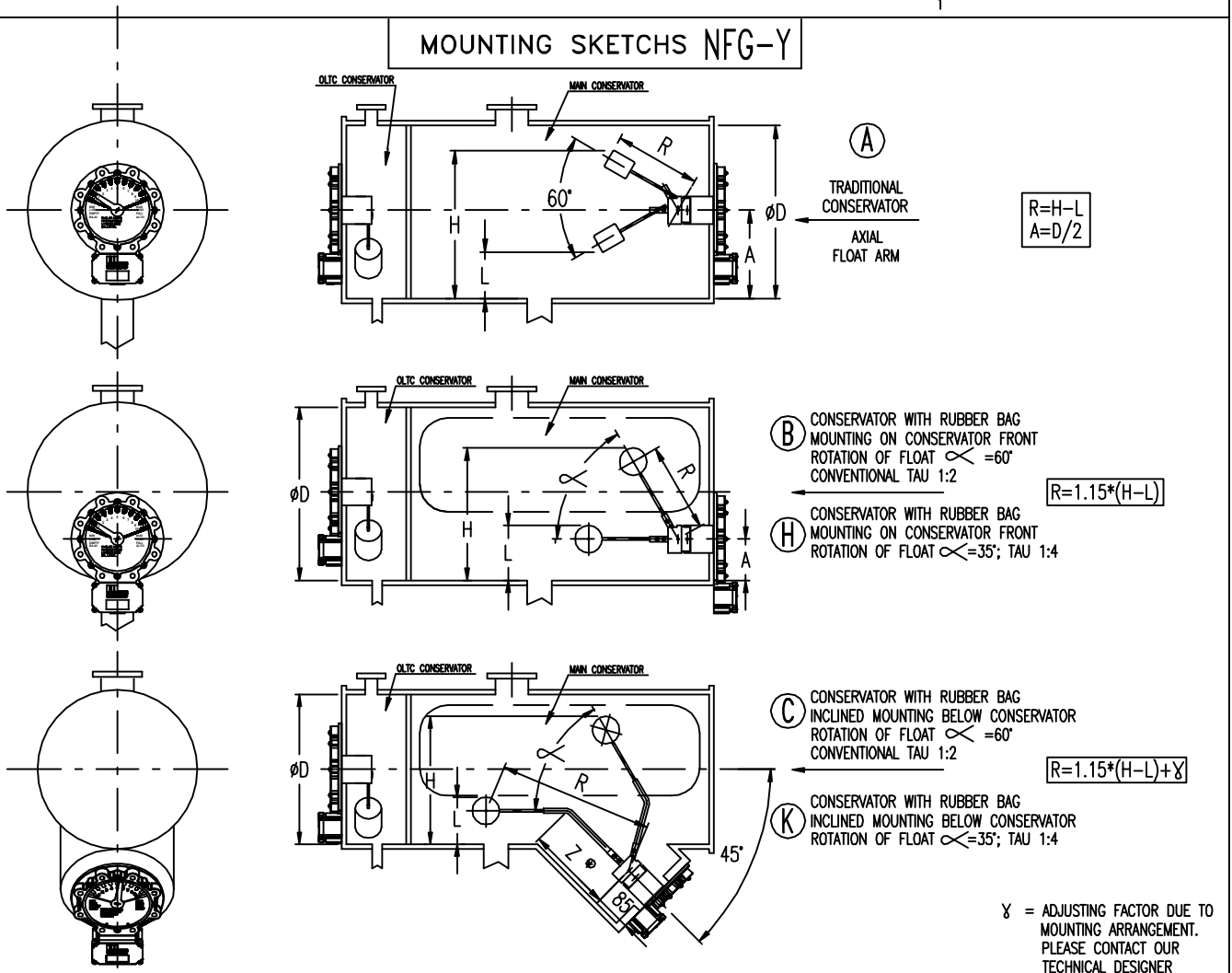

Y = ADJUSTING FACTOR DUE TO MOUNTING ARRANGEMENT. PLEASE CONTACT OUR TECHNICAL DESIGNER  
 \* = TO BE SPECIFIED ON ORDER

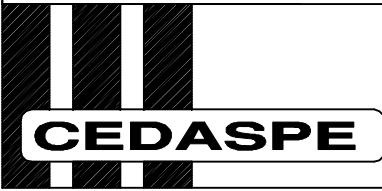

Titolo  
**Magnetic oil level indicator NFG**

Data 12/03/13  
 Scala ==  
 Dis.  
 Visto

Dis. Nr  
**3831**

1			
---	--	--	--

STYLE R

NFG 7

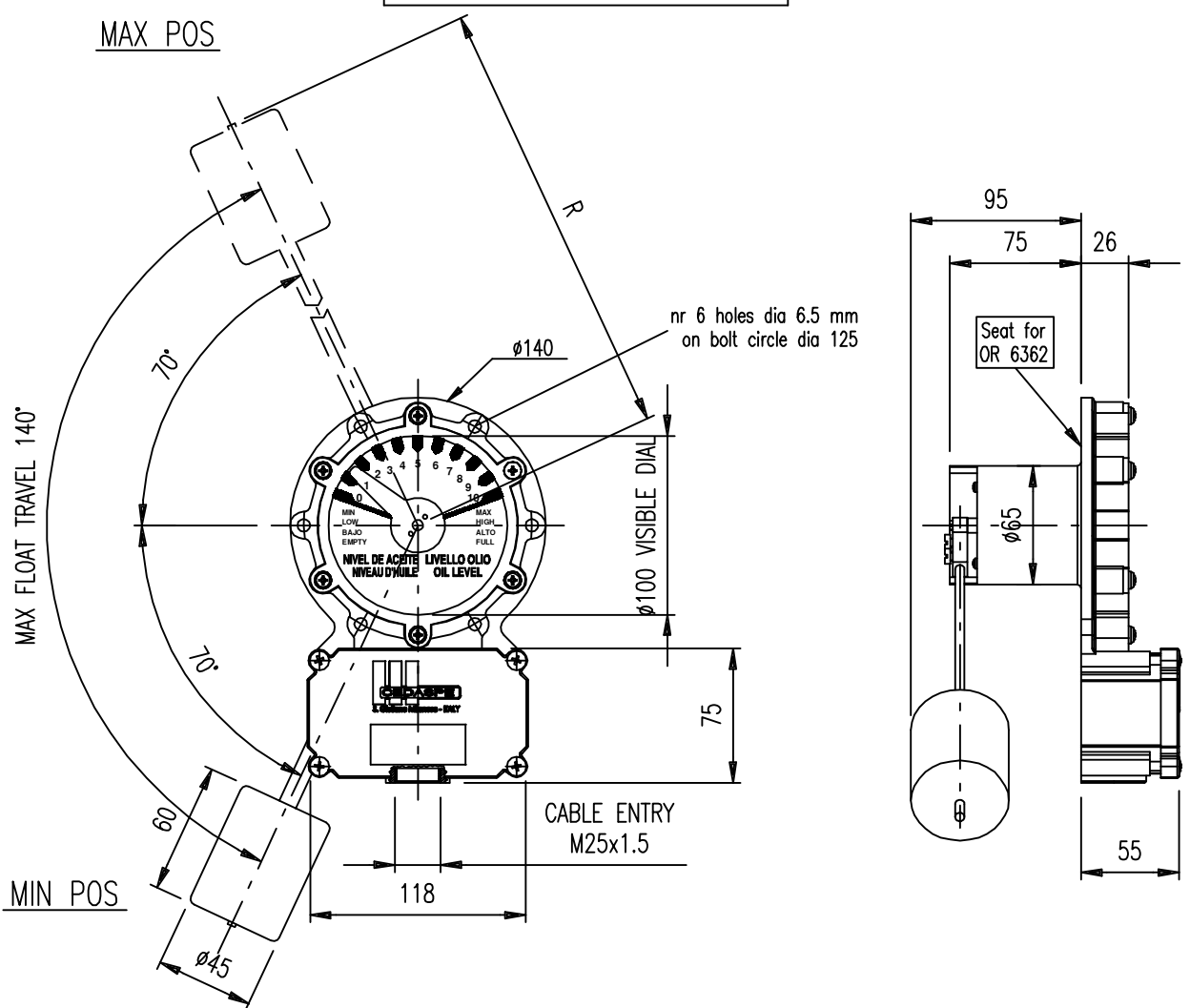

DIM. IN mm

STYLE Y

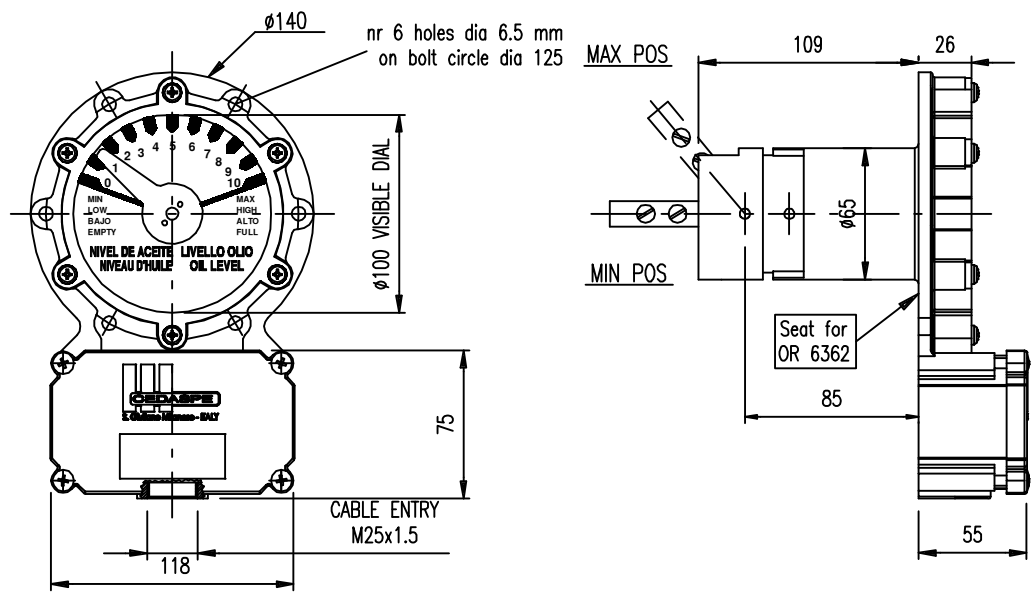

DIM. IN mm

Average weight R or Y: ~2 Kg

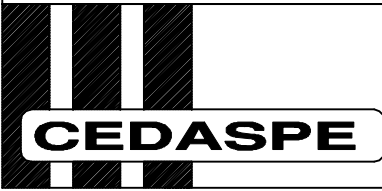

Titolo  
Magnetic oil level indicator NFG size 1

Data 12/03/13  
Scala ==  
Dis.  
Visto

Dis. Nr  
3832

1				
---	--	--	--	--

STYLE R

NFG 8

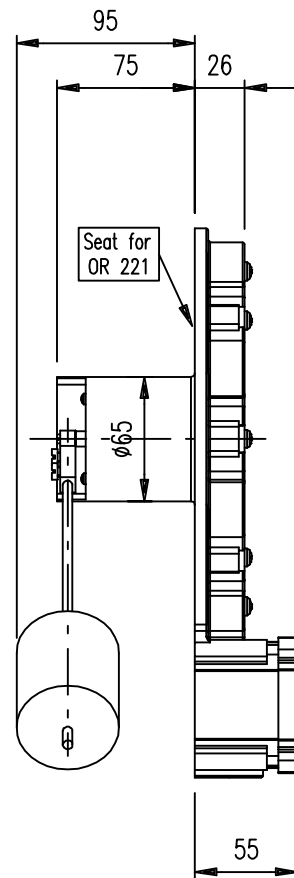
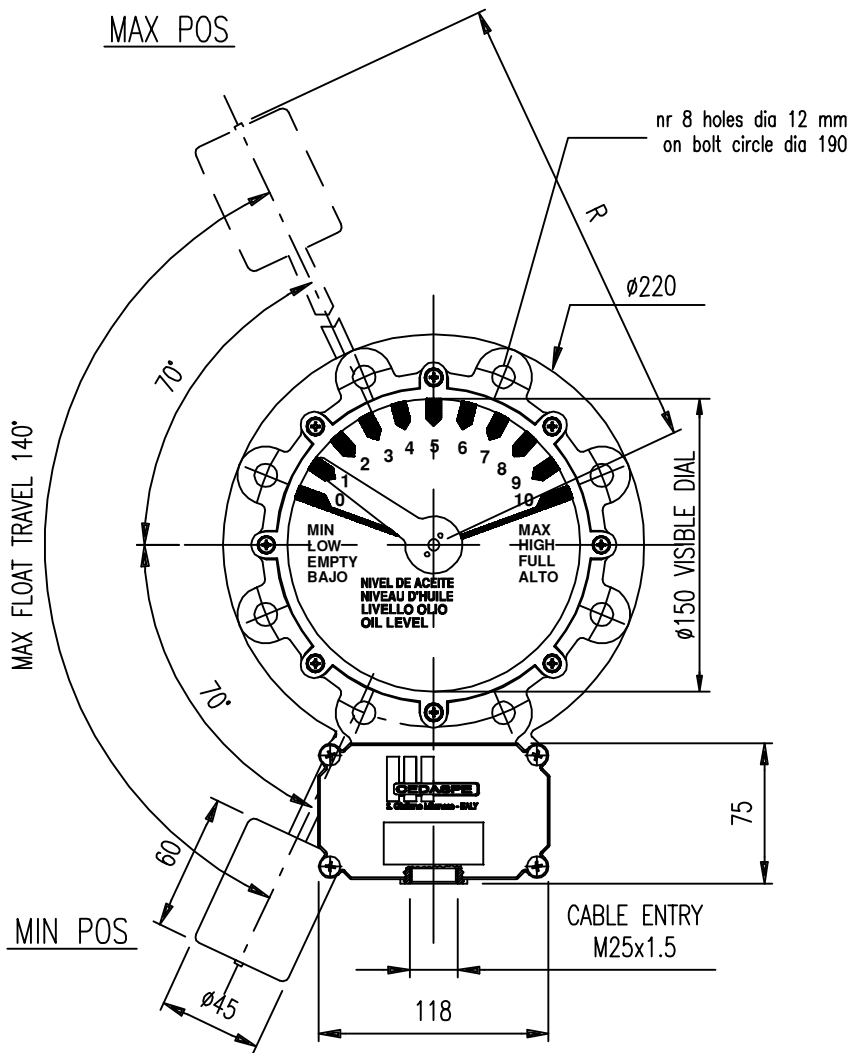

DIM. IN mm

STYLE Y

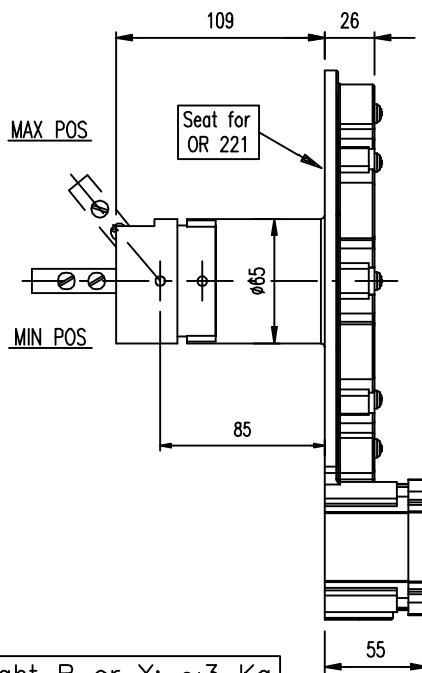
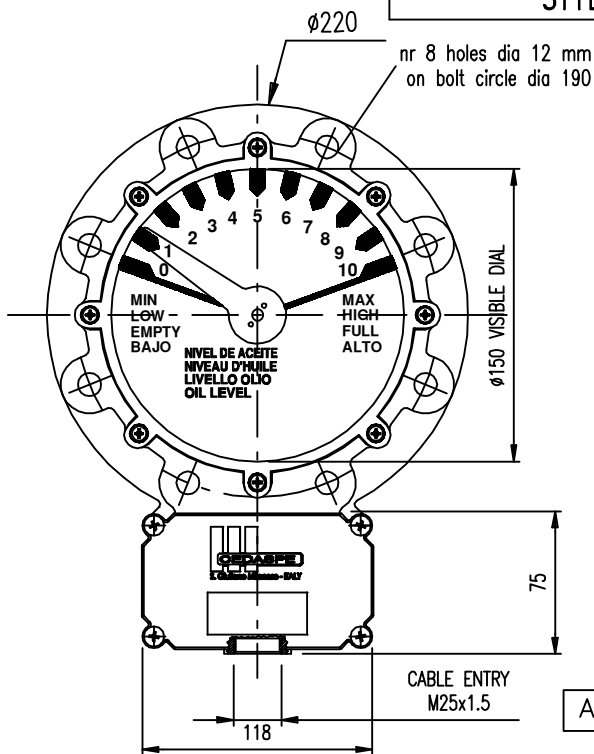

Average weight R or Y: ~3 Kg

DIM. IN mm

A4 (210x297)

LMF [(0,0) (196,286)]

FILE = 3833 .DWG

REV. 01 DTD 31/03/16

La CEDASPE S.p.A. si riserva a termini di legge la proprietà del presente disegno con divieto di riproduzione o comunicarlo a terzi senza sua autorizzazione.

**CEDASPE**

Titolo

Magnetic oil level indicator NFG size 2

Data 12/03/13

Scala ==

Dis.

Visto

Dis. Nr

3833

1



STYLE R

NFG 9

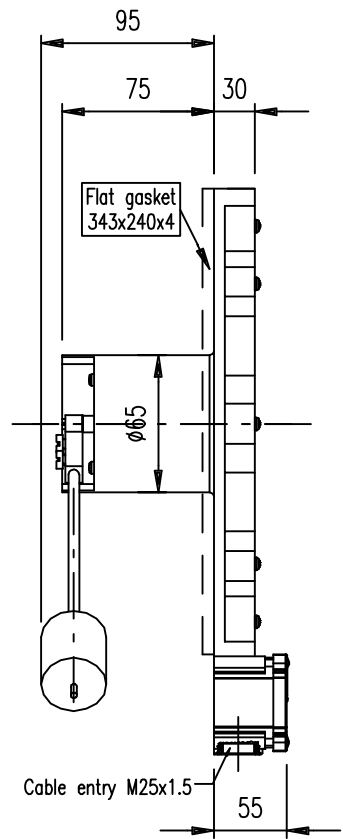
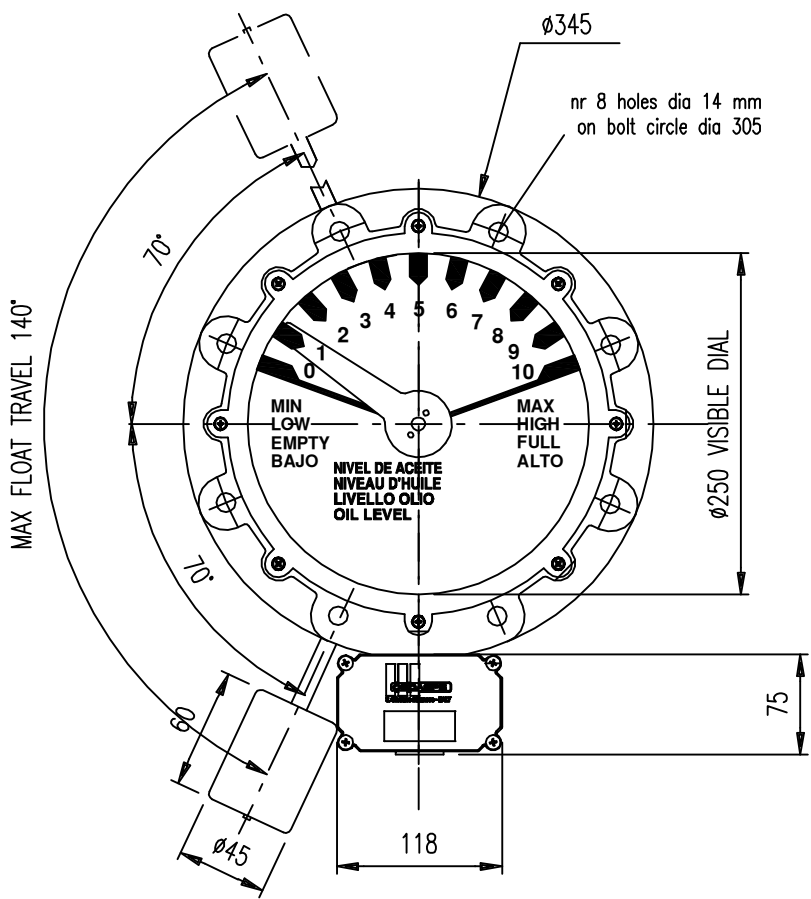

DIM. IN mm

STYLE Y

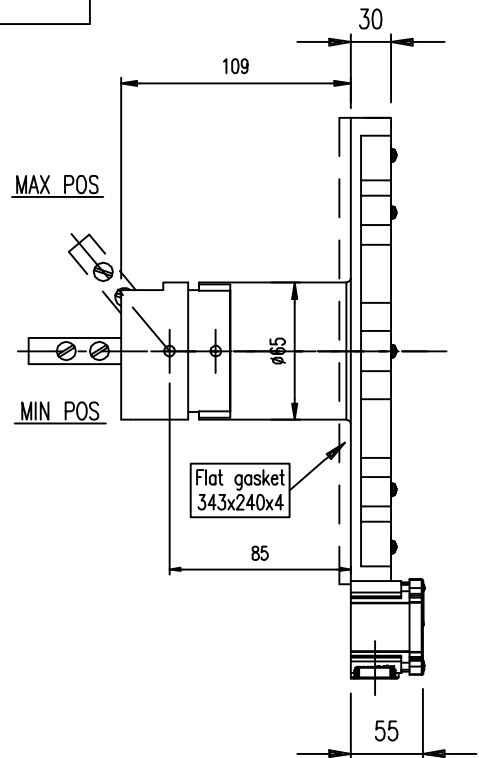
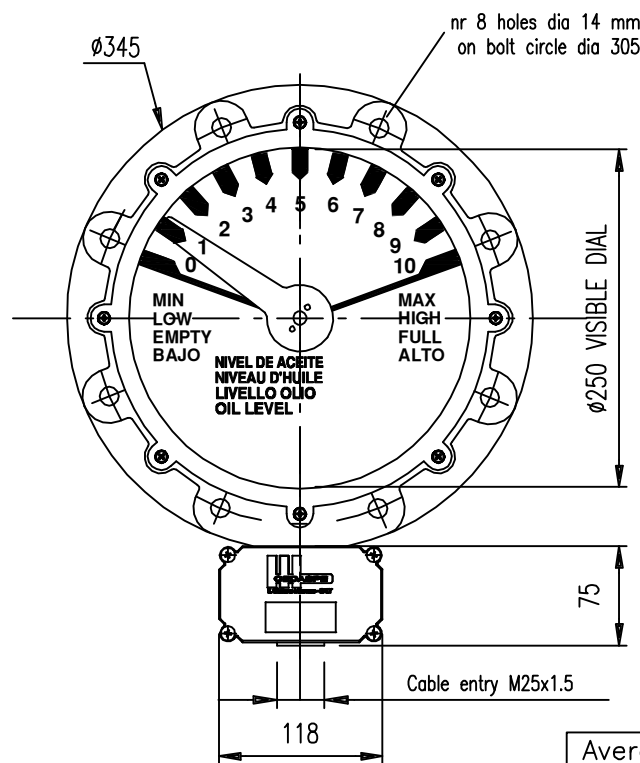

Average weight R or Y: ~6 Kg

DIM. IN mm

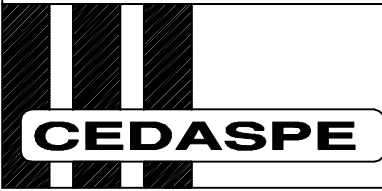

Titolo  
**Magnetic oil level indicator NFG size 3**

Data 12/03/13  
 Scala ==  
 Dis.  
 Visto

Dis. Nr  
**3834**

1				
---	--	--	--	--

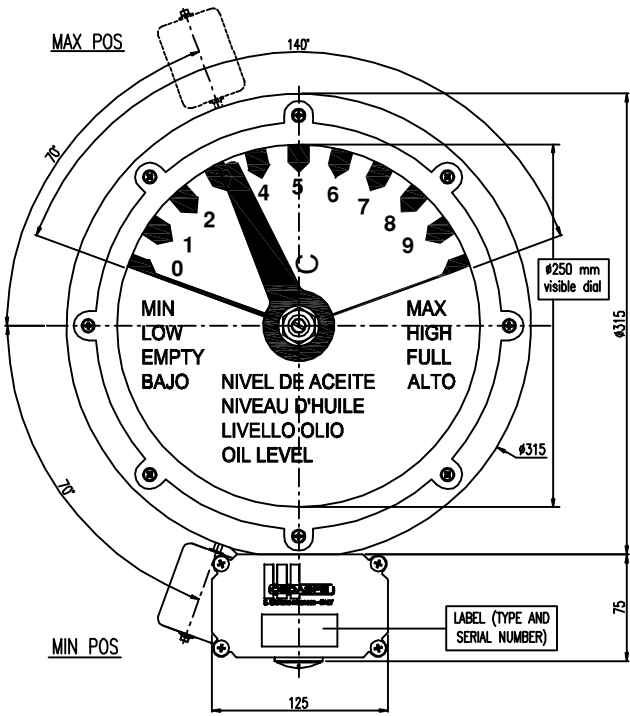
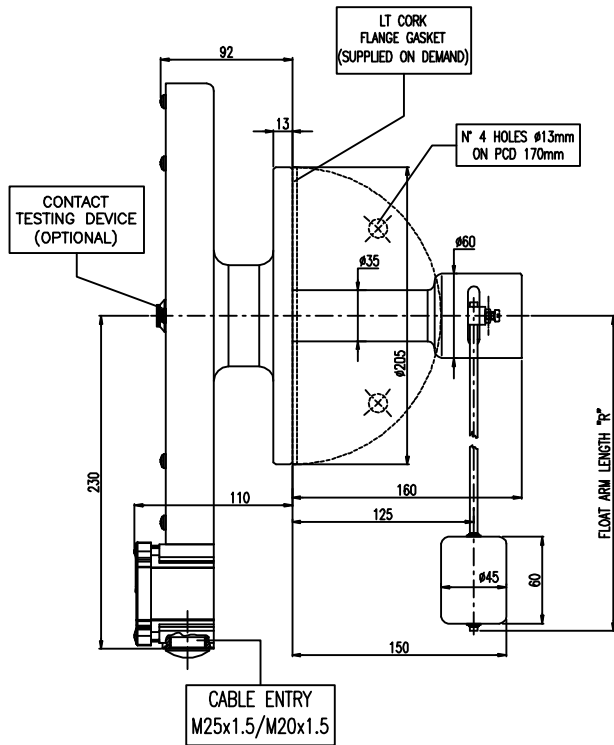

STANDARD DIALS

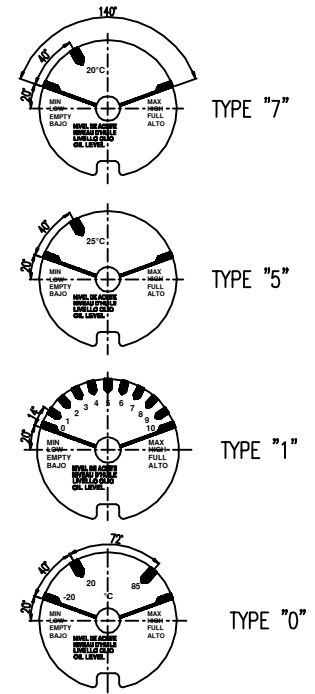

WIRING DIAGRAM C1 (MIN)

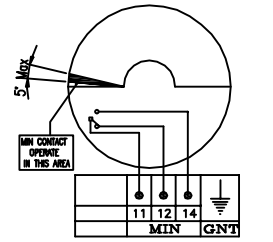

WIRING DIAGRAM C2 (MIN & MAX)

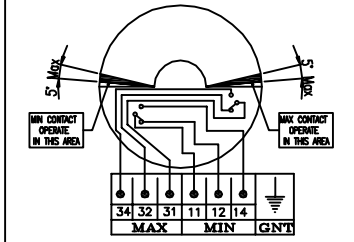

PERFORMANCE OF CONTACTS

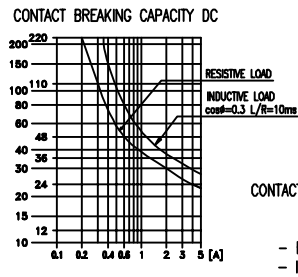

CONTACT BREAKING CAPACITY  
@ 250 VAC  
- Resistive load 5A  
- Inductive load 3A

MOUNTING SKETCH ON CONSERVATOR

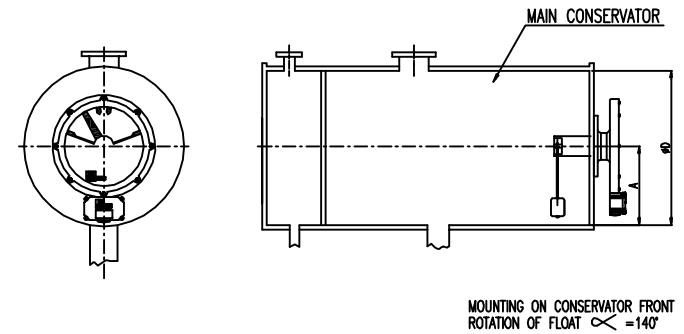

WIRING DIAGRAM D1 (MIN ALARM & TRIP)

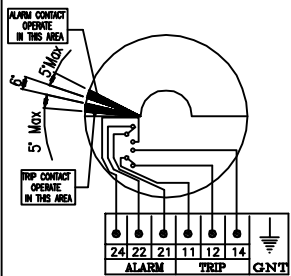

WIRING DIAGRAM D4 (DOUBLE MIN + DOUBLE MAX)

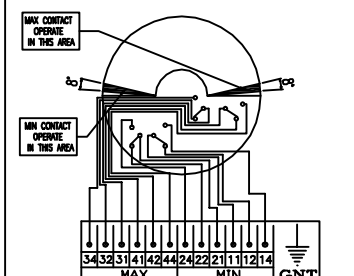

INDICATION LEVER

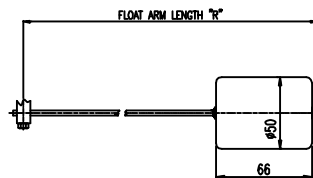

Ind.	Data	Modifica	Finitura		TOLLERANZA GENERALE UNI-ISO 2768	
			Trattamento		Qualità = □ m □ c □	
			Materiale Unific. Design.		Asieme =	
			Peso Grezzo		kg Codice grezzo =	
			Finito		kg Codice =	
Titolo			MOLG		Data 05/12/17	
			NFG-R-4		Scala 1:2	
					Dis. Nr 4397	
					Visto	

**CEDASPE**

STANDARD DIALS

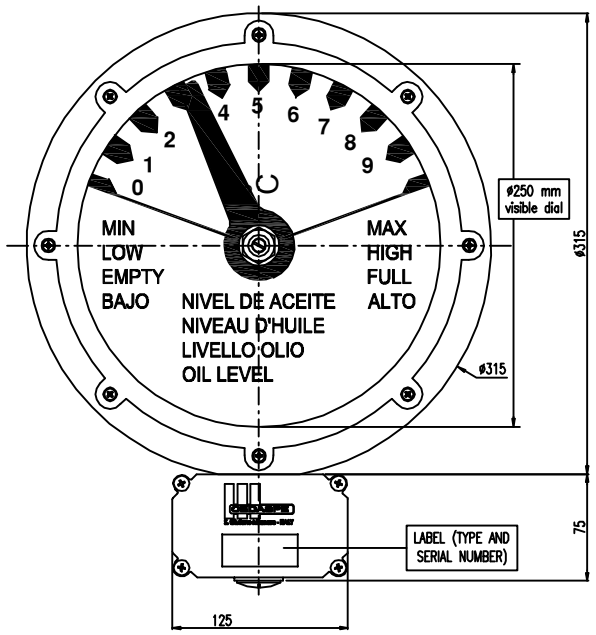
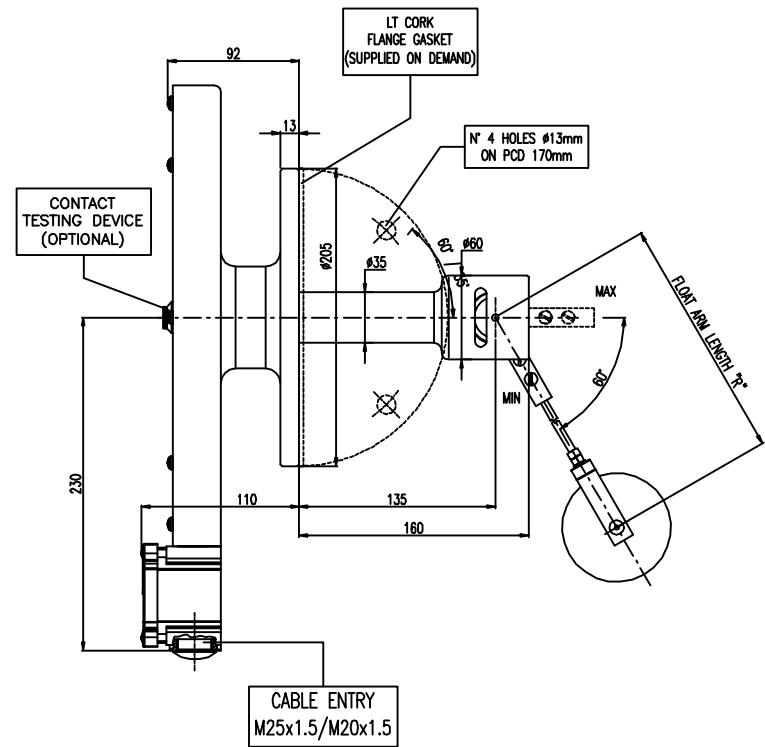
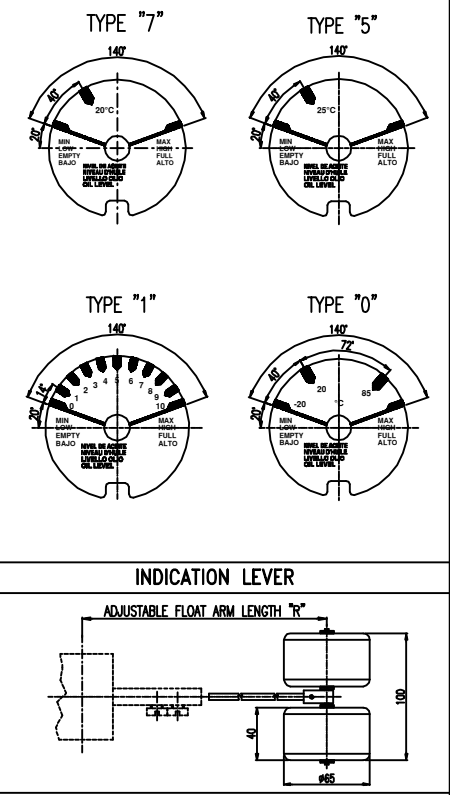

WIRING DIAGRAM C1 (MIN)

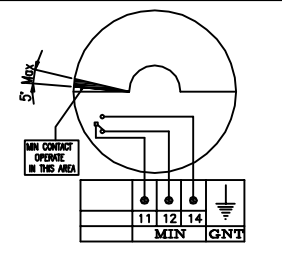

WIRING DIAGRAM C2 (MIN & MAX)

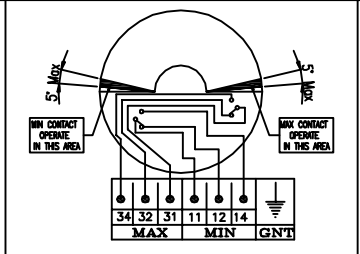

MOUNTING SKETCH ON CONSERVATOR WITH FLEXIBLE ENVELOPE

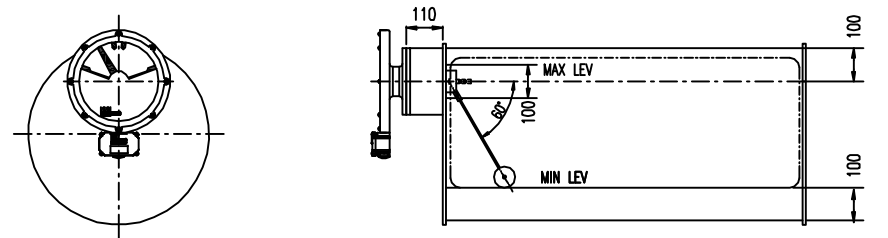

WIRING DIAGRAM D1 (MIN ALARM & TRIP)

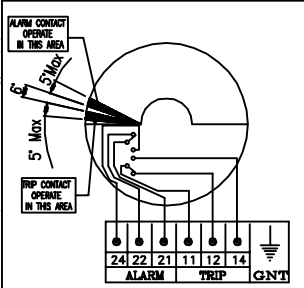

WIRING DIAGRAM D4 (DOUBLE MIN + DOUBLE MAX)

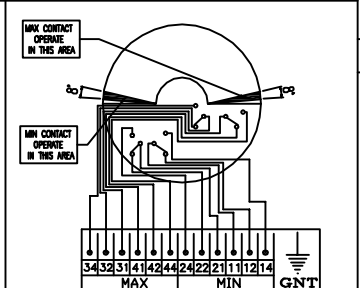

PERFORMANCE OF CONTACTS

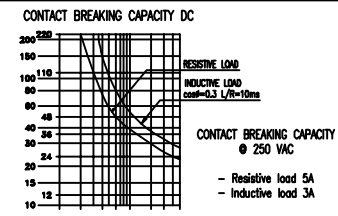

Ind.		Data		Modifica		Titolo		Finitura		TOLLERANZA GENERALE UNI-ISO 2768	
								Trattamento		Qualità = □ □ m □ □ □	
								Materiale Unific. Design.		Assieme =	
								Peso Grezzo		Codice grezzo =	
								Finito		Codice =	
								MOLG NFG-Y-4		Data 05/12/17	
										Scala 1:2	
										Dis. Nr 4398	
										Visto	



La CEDASPE S.p.A. si riserva a termini di legge la proprietà del presente disegno con diritto di riproduzione o comunicazione a terzi senza sua autorizzazione.

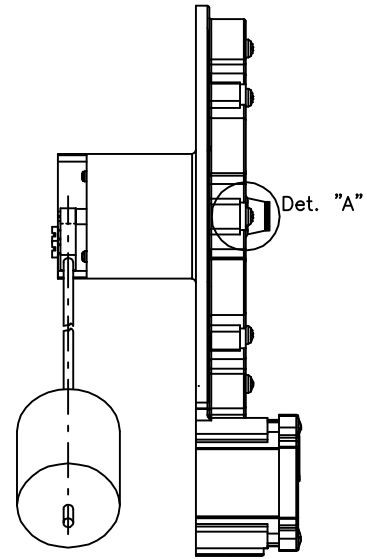
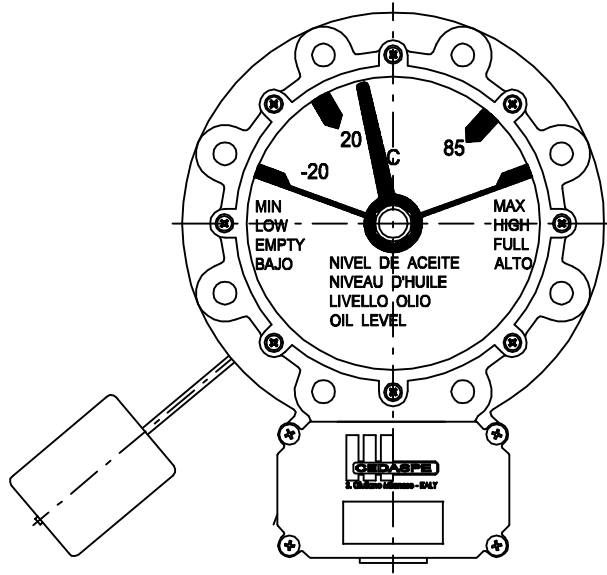

3	NFG3	50GP000300
2	NFG2	50GP000200
1	NFG1	50GP000100
Pos.	M.O.L.G.	Code

Picture shows O.L.I. type NFG R2 scale 1:4

7	OR2031		1	GGOR2031
6	Quadrante	3313	1	Vedi disegno
5	Tappo	3308	1	9TL900H0010
4	Mozzo Ch19	3310	1	9TL900H0030
3	Guarnizione	3311	2	Vedi disegno
2	Rondella Ottone	3312	1	ROT020SP01
1	Ghiera Ch19	3309	1	9TL900H0020
Pos.	Descrizione	Dwg	Q.ty	Codice

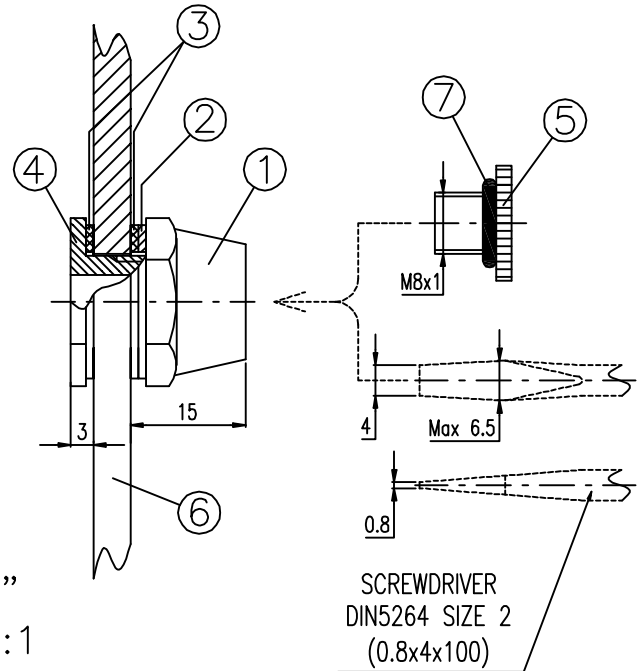

Det. "A"  
Scale 1:1

SCREWDRIVER  
DIN5264 SIZE 2  
(0.8x4x100)

			Finitura		TOLLERANZA GENERALE UNI-ISO 2768	
			Trattamento		Qualità = f <input type="checkbox"/> m <input checked="" type="checkbox"/> c <input type="checkbox"/>	
3	03/10/12	Rifatto disegno	Materiale	Unific. Design.	EX DIS. P2256 R.1	
2	25/10/10	Agg. tabella codici			Assieme =	
1	21/10/10	Rifatto disegno con nuovi particolari	Peso	Grezzo	kg	Codice grezzo =
Ind.	Data	Modifica		Finito	kg	Codice =
			Titolo <b>MOLG CONTACT TESTING FACILITY (UPON REQUEST)</b>		Data 19/11/09	
					Scala ==	
					Dis.	
					Visto	
					Dis. Nr 3283	
					1 2 3	

# ORDER FORM NFG-Y

AA (210x297)

LMT [(0,0) (196,286)]

.DWG

FILE = 3893

REV. 02 DTD 15/09/17

La CEDASPE S.p.A. si riserva a termini di legge la proprietà del presente disegno con divieto di riproduzione o comunicazione a terzi senza sua autorizzazione.

Type  NFG-Y1  NFG-Y2  NFG-Y3

Gasket type  N  C  G  SPECIAL

Wiring diagram  C1  C2  D1  D2

Dial  type "0" -20/20/85  type "1" 0÷10  type "5" 25°  SPECIAL

R: ..... L: ..... H: ..... Hmax: .....

Z\*: ..... ØD: ..... A: .....

\* Dimension to be specified only for executions C & K

*Note:*

.....

.....

.....

.....

*Special request:*

.....

.....

.....

.....

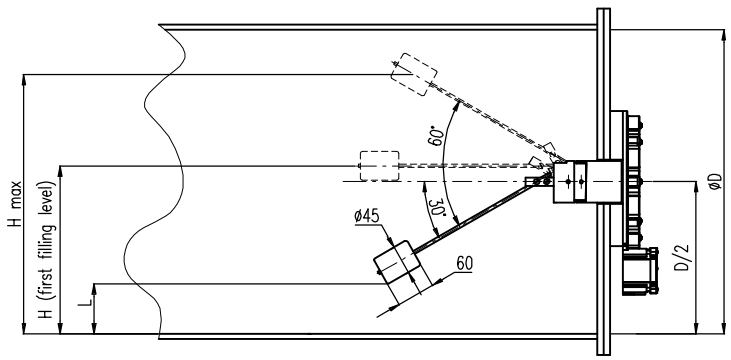

**(A)** Traditional conservator  
Axial float arm  
- Float arm acc. to Drg. 5608

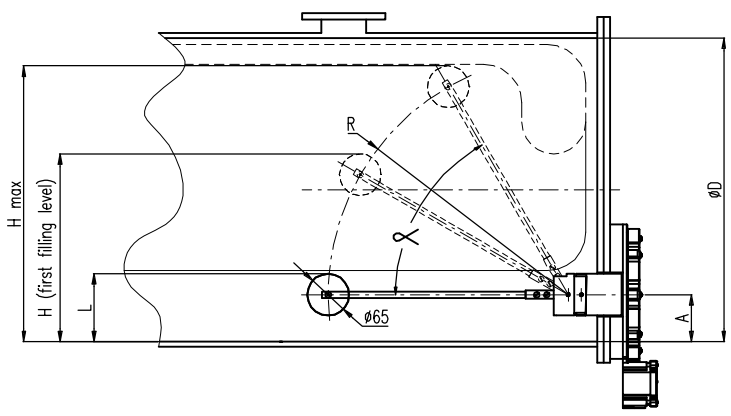

**(B)** Conventional Tau 1:2  $\alpha = 60^\circ$   
**(H)** Tau 1:4  $\alpha = 35^\circ$   
- Float arm acc. to Drg. 5607

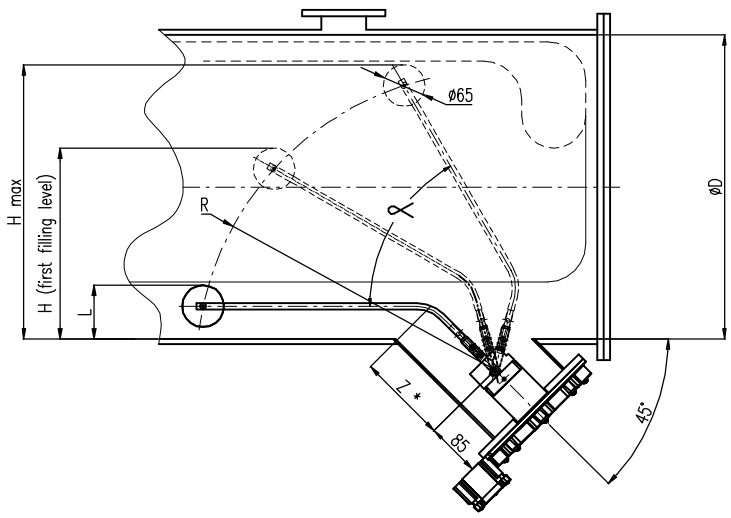

**(C)** Conventional Tau 1:2  $\alpha = 60^\circ$   
**(K)** Tau 1:4  $\alpha = 35^\circ$   
\* Dimension to be specified on order  
- Float arm acc. to Drg. 3181

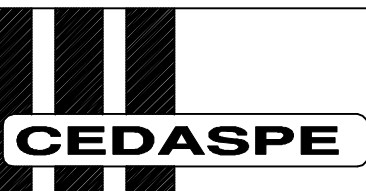

Titolo  
**Magnetic oil level indicator NFG-Y**

Data **30/09/13**  
Scala **====**  
Dis.  
Visto

Dis. Nr  
**3893**

1	2			
---	---	--	--	--

# ORDER FORM NFG-R

A4 (210x297)

LMF [(0,0) (196,286)]

FILE = 3831/1.DWG

REV. 02 DTD 26/10/17

La CEDASPE S.p.A. si riserva a termini di legge la proprietà del presente disegno con divieto di riprodurlo o comunicarlo a terzi senza sua autorizzazione.

Type  NFG-R1  NFG-R2  NFG-R3

Gasket type  N  C  G  SPECIAL

Wiring diagram  C1  C2  D1  D2

Dial  type "0"  type "1"  type "5"  SPECIAL  
-20/20/85      0±10      25°

*Note:* .....

.....

.....

.....

*Special request:*

.....

.....

.....

.....

.....

R: ..... D: ..... Hmax: ..... H: ..... H2: ..... H3: ..... L: .....

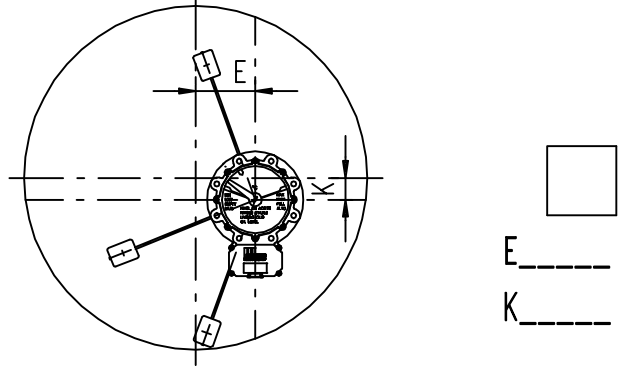
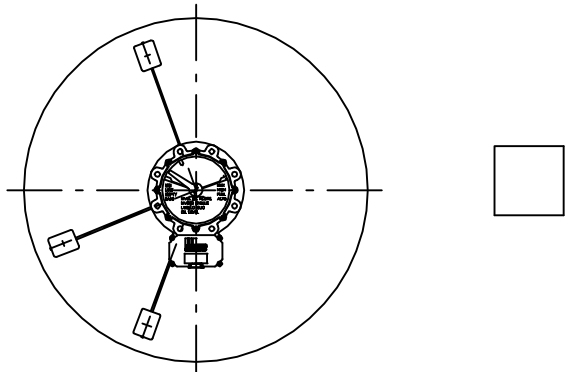
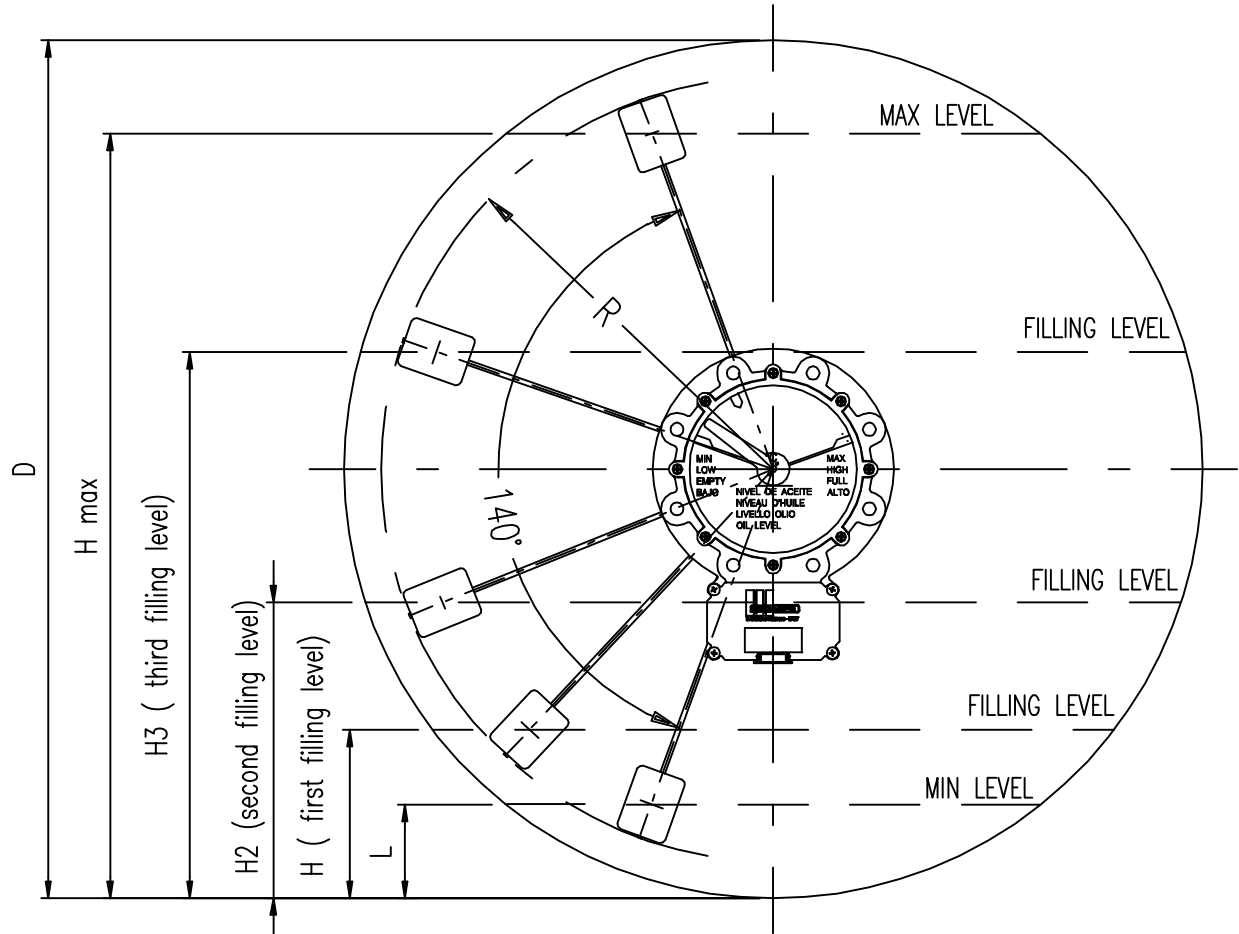

Titolo  
**Magnetic oil level indicator NFG-R**

Data 02/08/17  
 Scala ==  
 Dis.  
 Visto

Dis. Nr  
**3831/1**

1	2			
---	---	--	--	--