

# BUTTERFLY VALVES

## Isolation valves

The optimal solution for the easy and safe isolation of transformer piping components



### 3 Operating features

#### 3.1 Tightness of spindle

The tightness to oil leakage from the spindle on the butterfly valve, is guaranteed by a set of o/rings on the spindle and on the gland obtaining an excellent tightness and at the same time allowing an easy replacement of the gasket

**No leakage is tolerated from the spindle in any case.**

#### 3.2 Tightness of butterfly

##### 3.2.1 Metal to metal sealing (thin blade throttle)

The oil tightness of the butterfly is obtained by contact metal to metal, thus assuring a constant performance even after a long use .

Leakage at the butterfly is checked during assembly, testing with oil at 20° C, 1 bar and viscosity of 30,5 cSt.

Following values of max admitted leakage:

Nominal diameter of valve in mm	≤ 100	100 < > 175	≥ 175
Admitted leakage in dm <sup>3</sup> /h measured in 1 hour	≤ 0,5	≤ 1,0	≤ 2,0

##### 3.2.2 Full tightening sealing (TW80 with o-ring blade)

The oil tightness of the butterfly is obtained by contact of an o/ring (mounted on the throttle) and the metal body, thus assuring full sealing between throttle and body.

No leakage is present between throttle and body in closed position.

#### 3.3 Operating Torque

The operating torque measured by dynamometric spanner are the following :

Nominal diameter of valve in mm	≤ 100	100 < > 150	≥ 150
Operating torque in Nm.	≤ 10	≤ 30	≤ 30
Closing torque in Nm.	≤ 70	≤ 100	≤ 150
Opening torque in Nm.	≤ 40	≤ 50	≤ 50

**Operating torque:** Torque necessary to turn the shaft from the open to the closed position;

**Closing torque:** Torque necessary to obtain the complete closure of the valve;

**Opening torque:** Torque necessary to open the valve, after complete closure.

## 4 Admitted operating conditions

### 4.1 Standard execution (N) – Nitrile rubber gaskets

- Ambient conditions:
  - ◇ Ambient temperature: -20 °C to +50 °C
  - ◇ Relative humidity: 95% to 20 °C - 80% to 40 °C - 50% to 50 °C
- Insulating liquid and it's temperature:
  - ◇ Mineral oil: -20 °C to +110 °C
  - ◇ Silicone oil: -20 °C to +110 °C

### 4.2 Execution H – H-NBR rubber gaskets

- Ambient conditions:
  - ◇ Ambient temperature: -40 °C to +50 °C
  - ◇ Relative humidity: 95% to 20 °C - 80% to 40 °C - 50% to 50 °C
- Insulating liquid and it's temperature:
  - ◇ Mineral oil: -40 °C to +140 °C
  - ◇ Silicone oil: not admitted

### 4.3 Execution V – Fluor-rubber gaskets (Viton V)

- Ambient conditions:
  - ◇ Ambient temperature: -15 °C to +50 °C
  - ◇ Relative humidity: 95% to 20 °C - 80% to 40 °C - 50% to 50 °C
- Insulating liquid and it's temperature:
  - ◇ Mineral oil: -15 °C to +160 °C
  - ◇ Silicone oil: -15 °C to +160 °C

## 5 Mounting, Adjustment and Maintenance

### 5.1 Mounting

The throttle valve has to be mounted as shown on reference drawings or at page 5.86

Valve has to be mounted using screws or rods, washers and nuts and putting the o/ring on the groove for flange tightening

### 5.2 Operating instructions

The design of the operating system is common to all valves; to open and close the valve operate as follows (please refer to drawings):

- The visible symbol or inscription on plate (10) indicates the valve position;
- To close the valve first remove the seal or padlock (if present),
- With the appropriate spanner turn the drive (2) clockwise 90° to close the valve; counter clockwise 90°  
to open the valve
- The visible part of plate (10) indicates the actual valve position;

### 5.3 Maintenance

The Throttle valves do not need periodic maintenance; however it is advisable to check regularly the external tightening of valve

## 6 Range of types and reference drawings

The butterfly valves have standard execution flanges according to UNI PN10 and PN6; flanges according to other standards can be supplied as special execution.

Nominal diameters (DN) are 25;50;80;100;125;150;200;250;300

Below detailed list of available types

### 6.1 Series SW for radiators– metal to metal sealing (square flange – thin blade)

- Nominal diameter: 80 mm
- Execution
  - A1 & A0 Welding neck
  - B1 & B0 Wafer type for mounting between two flanges
- Reference drawing : page 5.82 & page 5.83
- Mounting sketch
  - A1 & A0 Welding neck : page 5.86 fig. A or B
  - B1 & B0 Wafer type for mounting between two flanges : page 5.86 fig. C or D
- Note: A1 & B1 flanges with groove for O/R 6400 (supplied with the valve)  
A0 & B0 flat flanges for flat gasket (supplied on demand)

### 6.2 Series TW for radiators – full tightening valve (square flange – o/ring blade)

- Nominal diameter: 80 mm
  - Execution wafer type for mounting between two flanges
- Reference drawing : page 5.81
  - Mounting sketch: page 5.86 fig. C or D

### 6.3 Series DN – round flange

- Nominal diameter: 25; 50; 80 mm
- Execution wafer type for mounting between two flanges
  - PN6 flange size : bolt circle diameter acc to UNI2276-67
  - PN10 flange size : bolt circle diameter acc to UNI2277-67
- Reference drawing : page 5.84
- Note : this kind of valves are delivered with HNBR gaskets for flange tightening

### 6.4 Series JU – large round flange

- Nominal diameter: 100;125;150;200;250;300 mm
- Execution wafer type for mounting between two flanges
  - PN10 flange size : bolt circle diameter acc to UNI2277-67
- Reference drawing : page 5.85

## 7 Order Specifications

When ordering it is necessary to indicate

- Series (type)
- Size
- Operating conditions (if not indicated, we will consider standard N)
- Special requirements

Example :

To order nr. 1 Throttle valve type DN50 PN6 standard execution please indicate the following:  
*Nr 1 Throttle valve DN50 PN6*

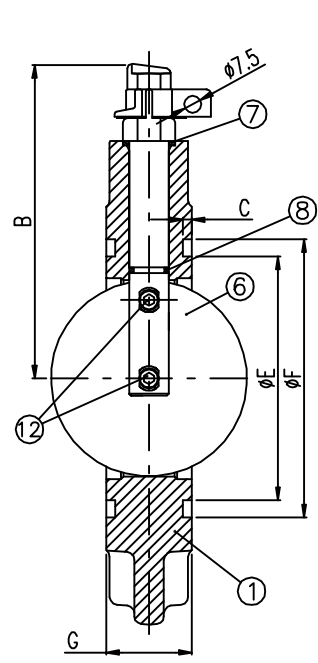
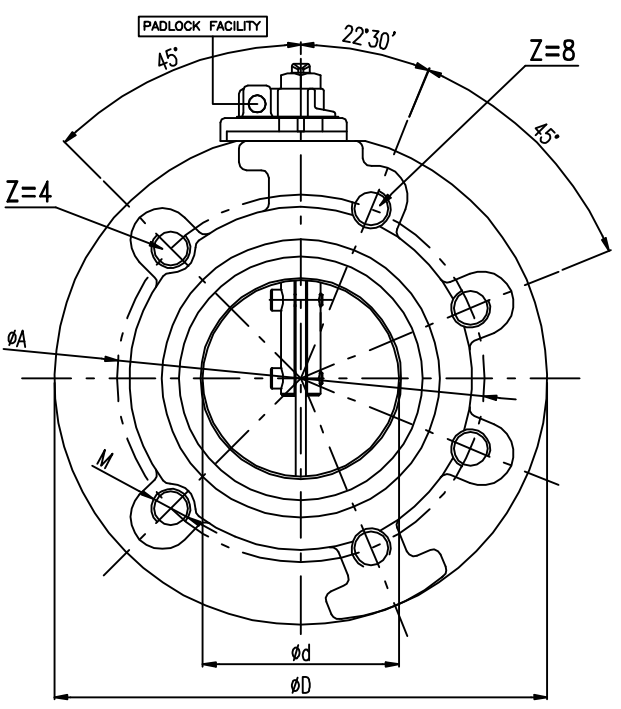

5.84

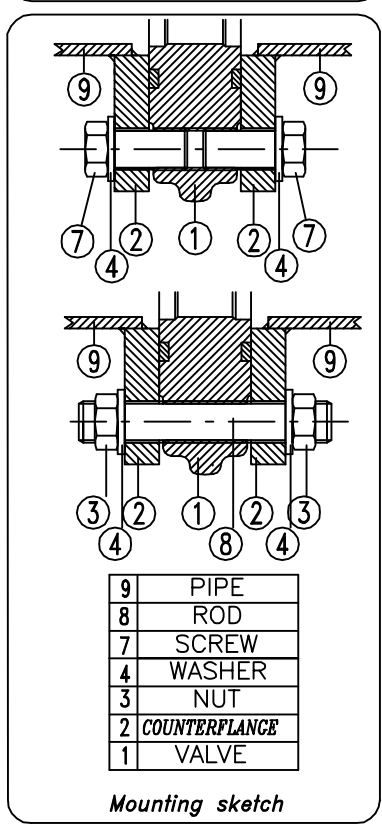
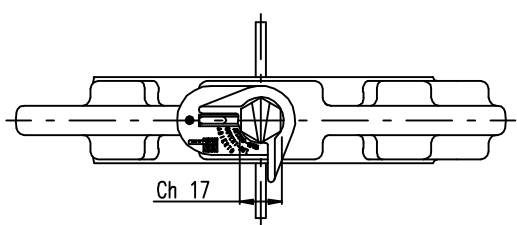
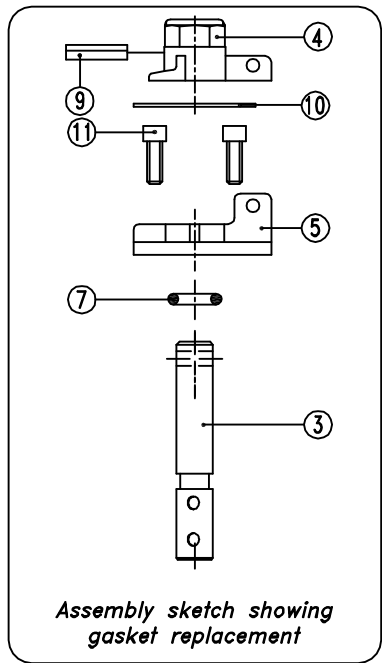

The present draw take place drawing PAC.5.76.D

Pos.	Description	Material	Note		
			DN25	DN50	DN80
1	Body	Steel			
3	Spindle	Steel			
4	Drive	Brass			
5	Gland	Brass			
6	Throttle	Steel			
7	O-ring	HNBR	OR115	OR121	OR121
8	O-ring	HNBR	OR108	OR2050	OR2050
9	Pin	Stainless Steel			
10	Label open/closed	Aluminium			
11	Screw	Stainless Steel			
12	Rivet	Stainless Steel			

Type	Ød	ØD	ØA	B	G	M	Z	C	ØE	ØF	Flange O-Ring	G.W. Kg	Screw DIN 933 pos.7	Rod pos.8	Code
DN25 PN6	28	115	75	85	25	M10	4	3.6	37	51	6150	1.5	M10X20	M10x90	AVPN06A025
DN25 PN10	28	115	85	85	25	M12	4	3.6	37	51	6150		M12X25	M12x90	AVPN10A025
DN50 PN6	52	165	110	110	35	M12	4	3.6	68.5	82.5	6275	3.5	M12X30	M12x100	AVPN06A050
DN50 PN10	52	165	125	110	35	M16	4	3.6	68.5	82.5	6275		M16X35	M16x110	AVPN10A050
DN80 PN6	80	200	150	130	35	M16	4	3.6	99.5	113.5	6400	5.5	M16X35	M16x110	AVPN06A080
DN80D PN10	80	200	160	130	35	M16	8	3.6	99.5	113.5	6400		M16X30	M16x120	AVPN10A081
DN80U PN10	80	200	160	130	35	M16	4	3.6	99.5	113.5	6400		M16X30	M16x120	AVPN10A080



Titolo  
**Throttle valve**  
 type DN25/DN50/DN80

Data 12/03/13  
 Scala ==  
 Dis.  
 Visto

Dis. Nr  
**3843**

1	2	3		
---	---	---	--	--

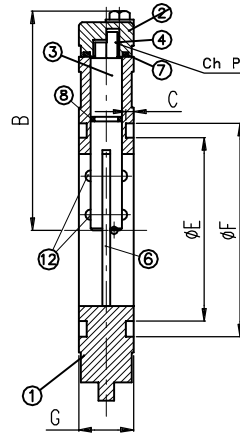
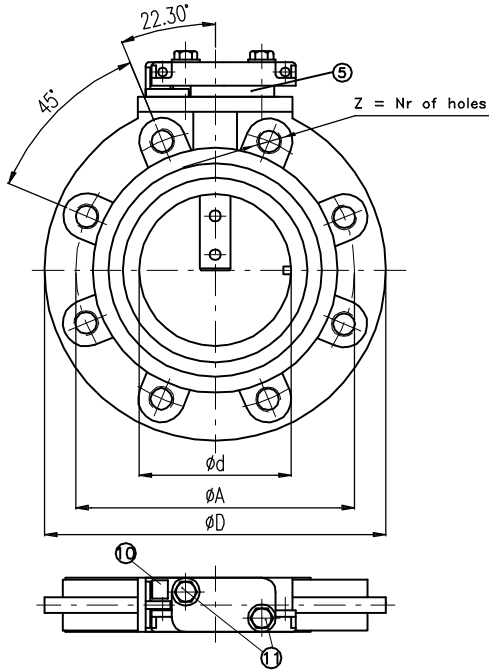

Pos	Description	Material
1	Body	Steel epoxy paint finishing
2	Spindle protection	Nylon
3	Spindle	Brass
4	Drive	Brass
5	Gland	Brass
6	Throttle	Steel
7	O-ring	NBR
8	O-ring	HNBR
10	Label open/closed	Aluminium
11	Screw	Stainless Steel
12	Rivet	Stainless Steel

THROTTLE VALVE JUZ 125350

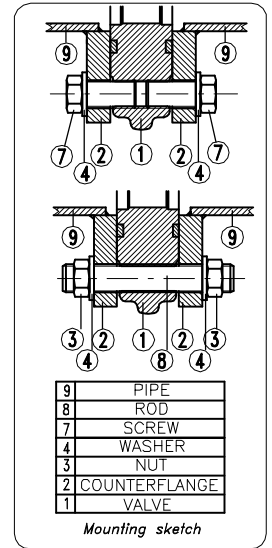
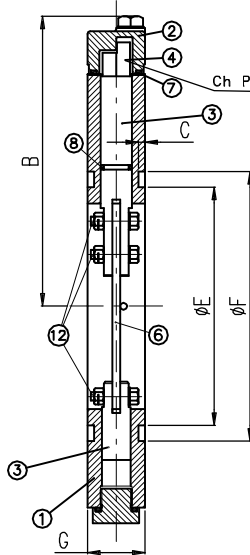
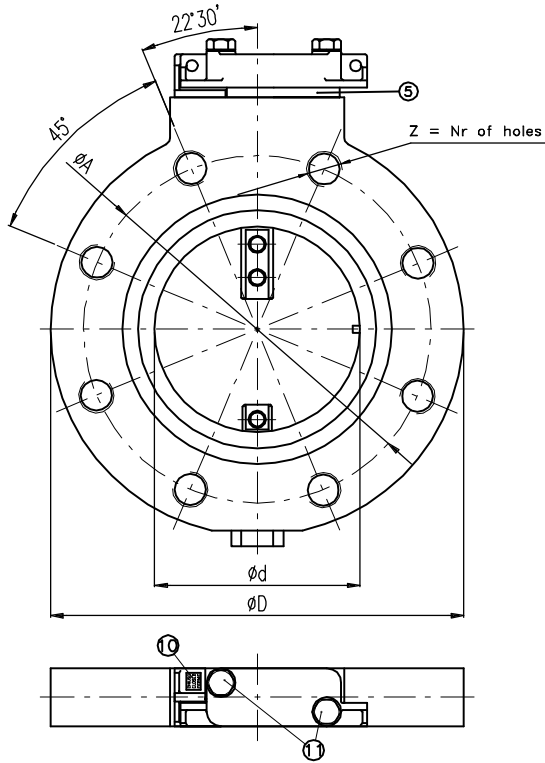

Type	$\phi d$	$\phi D$	$\phi A$	B	G	M	Z	P	C	$\phi E$	$\phi F$	(NBR) O-Ring	G.W Kg	Screw DIN 933 pos.7	Rod pos.8	Code
JU Z 100 (EPX)	98	220	180	150	35	M16	8	14	4.7	128	147	8525	9	M16X30	M16X130	AVRA100JU0
JU Z 125 (EPX)	124	250	210	175	40	M16	8	19	4.7	154	173	8625	13	M16X40	M16X130	AVRA125JU0
JU Z 150 (EPX)	149	285	240	195	40	M20	8	19	4.7	186	205	8750	16	M20X40	M20X130	AVRA150JU0
JU Z 175 (EPX)	174	315	270	208	40	M20	8	19	4.7	211	230	8850	19	M20X40	M20X130	AVRA175JU0
JU Z 200 (EPX)	198	340	295	219	40	M20	8	19	4.7	237	256	8950	21	M20X40	M20X130	AVRA200JU0
JU Z 250 (EPX)	249	395	350	244	40	M20	12	19	4.7	287	306	81150	29	M20X40	M20X130	AVRA250JU0
JU Z 300 (EPX)	299	445	400	270	60	M20	12	24	4.7	338	357	81350	50	M20X50	M20X150	AVRA300JU0
JU Z 350 (EPX)	348	505	460	310	60	M20	16	24	4.7	376 404	395 423	81500 81600	59	M20X50	M20X150	AVRA350JU0

The present draw take place drawing PAG.5.76.F

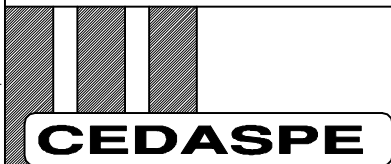

Titolo

Throttle valve  
type JU

Data 12/03/13

Scala ==

Dis.

Visto

Dis. Nr

3844

LATO TRASFORMATORE  
TRANSFORMER SIDE

LATO RADIATORE  
RADIATOR SIDE

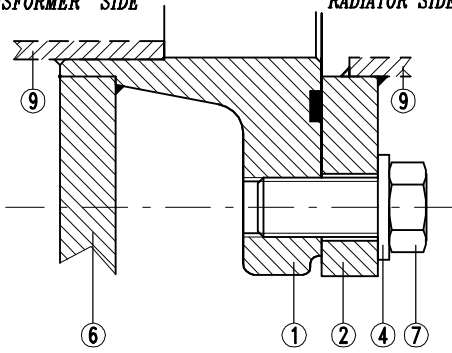

FIG.A

LATO TRASFORMATORE  
TRANSFORMER SIDE

LATO RADIATORE  
RADIATOR SIDE

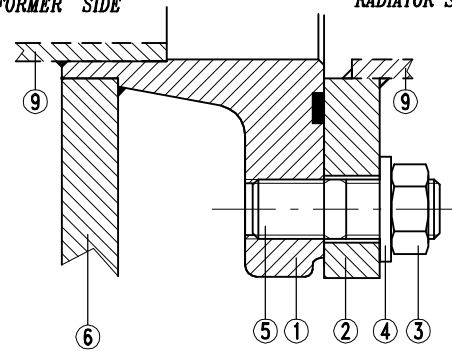

FIG.B

**MOUNTING KIT**

CODE: AVZT130A00

Montaggio tra due flange / Mounting between flanges

LATO TRASFORMATORE  
TRANSFORMER SIDE

LATO RADIATORE  
RADIATOR SIDE

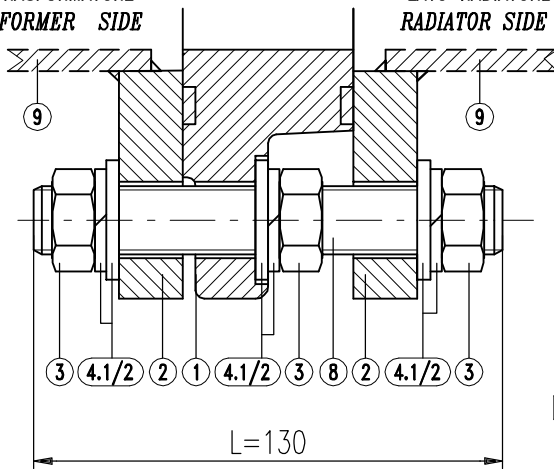

FIG.C

LATO TRASFORMATORE  
TRANSFORMER SIDE

LATO RADIATORE  
RADIATOR SIDE

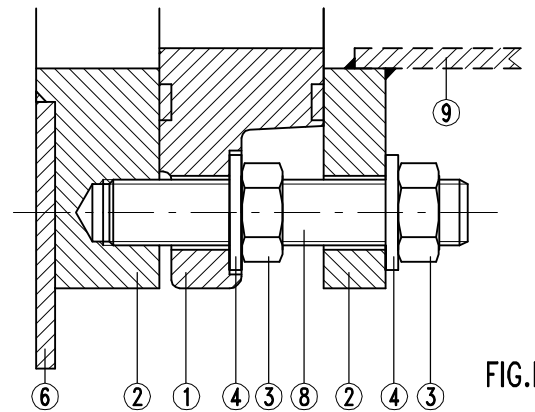

FIG.D

9	TUBO	TUBO	TUBO	TUBO
8	//	//	TIRANTE M16 X 130	TIRANTE M16 X 90
7	VITE T.E. M16X35	//	//	//
6	CASSA TRASFORMATORE	CASSA TRASFORMATORE	//	CASSA TRASFORMATORE
5	//	PRIGIONIERO M16X30	//	//
4.2	//	//	RONDELLA GROWER	//
4.1	ROSETTA PIANA M16	ROSETTA PIANA M16	ROSETTA PIANA M16	ROSETTA PIANA M16
3	//	DADO M16	DADO M16	DADO M16
2	CONTROFLANGIA	CONTROFLANGIA	CONTROFLANGIA	CONTROFLANGIA
1	VALVOLA	VALVOLA	VALVOLA	VALVOLA
Pos.	FIG.A	FIG.B	FIG.C	FIG.D

9	PIPE	PIPE	PIPE	PIPE
8	//	//	ROD M16 X 130	ROD M16 X 90
7	SCREW M16X35	//	//	//
6	TRANSFORMER TANK	TRANSFORMER TANK	//	TRANSFORMER TANK
5	//	STUD M16X30	//	//
4.2	//	//	SPRING WASHER	//
4.1	WASHER M16	WASHER M16	WASHER M16	WASHER M16
3	//	NUT M16	NUT M16	NUT M16
2	COUNTERFLANGE	COUNTERFLANGE	COUNTERFLANGE	COUNTERFLANGE
1	VALVE	VALVE	VALVE	VALVE
Pos.	FIG.A	FIG.B	FIG.C	FIG.D

The present draw take place drawing PAC.5.76.N

Titolo

Radiator valve  
- Mounting sketch -

Data 12/03/13

Scala == ==

Dis.

Visto

Dis. Nr

3845

1

**CEDASPE**

FILE = 3845 .DWG LMT [(0,0) (196,286)] A4 (210x297)

REV. 01 DTD 09/06/14

La CEDASPE S.p.A. si riserva a termini di legge la proprietà del presente disegno con divieto di riproduzione o comunicarlo a terzi senza sua autorizzazione.

La CEDASPE S.p.A. si riserva a termini di legge la proprietà del presente disegno con divieto di riproduzione o comunicarlo a terzi senza sua autorizzazione.

# ORDER FORM

A4 (210x297) LMF [(0,0) (196,296)] .DWG FILE = 4408 REV. 00 DTD 05/12/17 La CEDASPE Power S.r.l. si riserva o termini di legge la proprietà del presente disegno con divieto di riproduzione o comunicazione a terzi senza sua autorizzazione.

**DN Type**

**JUZ Type**

Size:

(8 Holes)

(12 Holes)

(16 Holes)

25

50

80 (4 Holes)

80 (8 Holes)

PN6

PN10

100

125

150

175

200

250

300

350

Operating conditions:

STANDARD  
(Mild steel Zinc-Plated)

OFF-SHORE  
(S/S AISI 316)

Gasket:

NBR  
(-25°C)

HNBR  
(-45°C)

Fluorosilicone Blue  
(-60°C)

Heavy Duty  
(VITON)

Colour:

RAL7030

RAL7031

RAL7032

RAL7033

RAL7035

RAL7036

RAL7038

RAL7040

RAL7044

RAL9002

ANSI70

Notes:

.....  
 .....  
 .....  
 .....  
 .....  
 .....  
 .....  
 .....  
 .....  
 .....  
 .....  
 .....  
 .....  
 .....

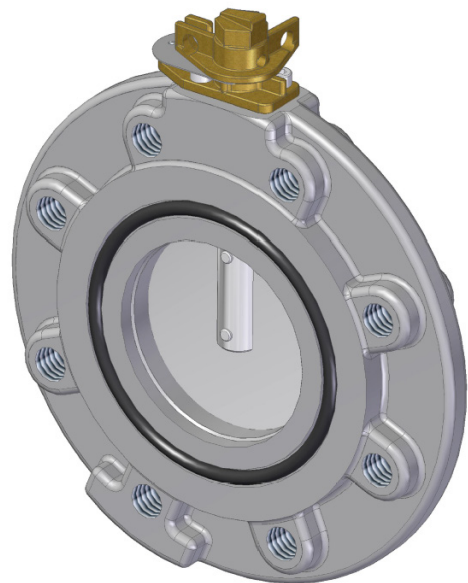

Titolo  
**Isolation valves  
 Order sheet**

Data 05/12/17  
 Scala =====  
 Dis.  
 Visto

Dis. Nr  
**4408**